



# COVER FRAMELESS GLASS

## Clearview Sliding Stacking System

*A versatile frameless, sliding, stacking glass system with compact profiles.*

## PRODUCT BENEFITS

### Aesthetics

- Smooth crisp lines (esthetically pleasing to look at)
- Aluminum profiles smaller in size comparing it to other similar systems.
- Clear weather strips between glass panels
- Wide range of colours available
- Un-obstructive view
- Adding value to your property

### Versatile

- totally retractable
- 95% opening usage
- All year use
- Many shapes (straight, curved, corners)
- Open inwards or outwards
- Open left, right or both ways
- Heights up to 2400mm
- Can accommodate any curtaining or blinds (short guider-arm protruding)

### Weather proofing

- Weather resistant wool-pile strips on in & outside of top profile
- Minimum clearance between profiles to reduce penetration risk
- Weather resistant wool-pile strip on outside of bottom track
- Build-in drain channel on inside of bottom track
- Triple wool-pile strips on closing side of system
- Double wool-pile strips on opening side of system.
- Unique rotating cam-lock action to stabilize opening panel against wind loads.
- Unique weather strips in between panels
- Clear and UV resistant (Will not go yellow or become brittle)
- Soft silicone inserts to prevent water and wind penetration
- No rattling
- 5 year guarantee on strips
- Interlocking plastic caps between panels
- Weather resistant shoulder on outside
- Drain pipes installed every 2000mm to run off any excess water penetration

### Safety & Security

- Internal sliding locks on top and bottom profiles of opening panel
- Stainless steel key-locks available as well
- 8mm – 10mm Toughened glass
- 5 times stronger than normal safety glass
- Lifetime guarantee on glass
- Strong and sturdy profiles
- 6005 grade Aluminium used
- 316 grade stainless steel bolts
- Structural glue and s/steel mechanical fixing used to secure glass to aluminum beads
- Intruder proof

# Exceeding Expectations since 1997

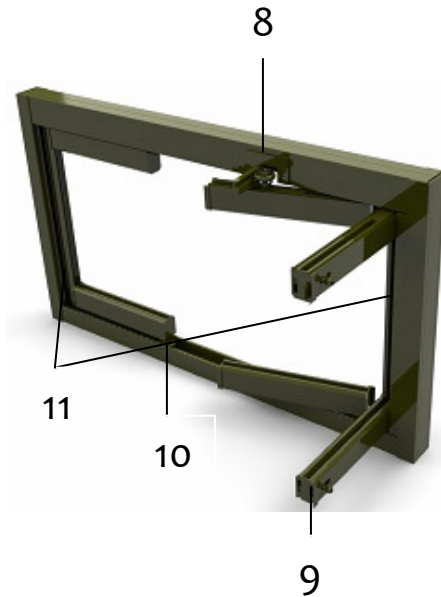
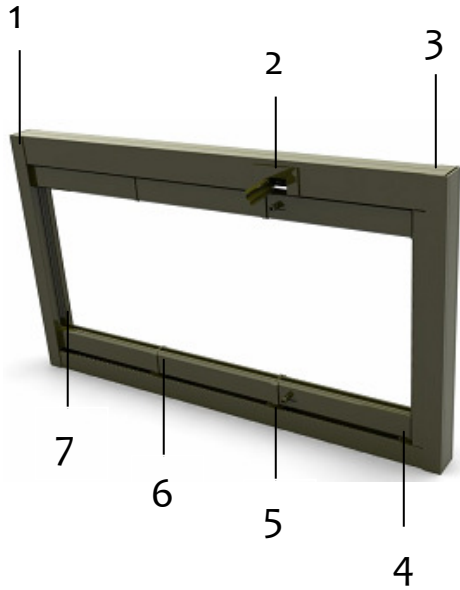

## Nr 1&3

Side compensating channel which allows vertical adjustment for structures out of level. The top and bottom profiles are inserted into the side compensating channels which prevents any water leakage



## Nr 7

Side box closing section with double wool-pile inserts to prevent water and wind penetration.

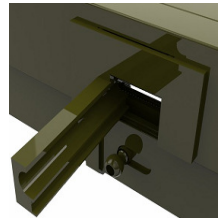

## Nr 2

The guider-arm is very compact and only protrude 60mm. This is ideal for fitment of blinds or curtains with the system.

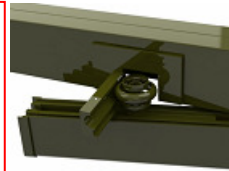

## Nr 8

Guider arm guides wheel assembly in and out of the head profile. The unique locking system locks the panels in to place preventing it from falling forward when opening the panels.

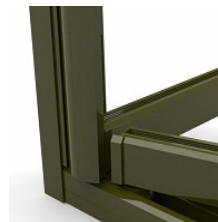

## Nr 4

Side opening box section that allows adjustment up to 15mm of. This eliminates additional cladding when walls are out of level.

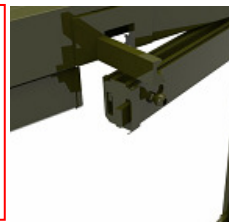

## Nr 9

Internal locking mechanism in opening panel beads with sliding knob top & bottom.

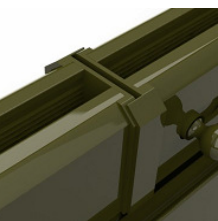

## Nr 5

Opening end caps has been uniquely design that interlocks to strengthen the system and prevent water and wind penetration.

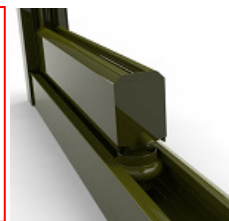

## Nr 10

Compact bottom sill to ensure a safe and user friendly threshold. Built-in drain channel on inside to ensure no water penetration. Thick aluminium wall to ensure structural integrity.

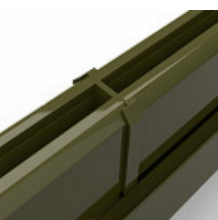

## Nr 6

Male and female end caps interlocks to strengthen the system and prevent water and wind penetration.



## Nr 11

Opening & Closing channels on 1<sup>st</sup> and last panel to improve weatherproofing and strengthen the panels. Interlocks into opening and closing boxes.



since  
1997

### **Glass**

The standard glass used in the sliding stacking system is 8mm toughened glass although 10mm & 12mm can be used with different glazing beads. The 8-12mm toughened glass can be described as thermally toughened soda lime silicate safety glass. Toughened safety glass is ideal for bolted structural glazing and frameless applications. Toughened glass meets the safety glass requirements of the South African National Building Regulations and can be obtained from accredited suppliers only.

Toughened glass is produced by heating annealed glass in a furnace to approximately 700°C and then rapidly blowing cool air onto both surfaces. This rapid cooling process is the key element in the physical changes in annealed glass that creates toughened glass.

Toughened glass are up to 500% stronger than annealed glass and therefore is more resistant to thermal breakage and can withstand greater wind loads. It can break, under extreme loads or by severe impact. On breaking it fragments into many small harmless pieces unlike annealed glass, thus minimising the chance of injury. It can be used within a temperature range of minus 70°C to plus 300°C (surface temperature should not exceed 250°C if other surface is lower than 0°C ambient)

### **Aluminium**

All structural aluminium profiles for the products will be manufactured in 6005 grade (best grade available) aluminium. This excludes cladding material such as flats & angles.

### **Steel components**

All steel components for the products will be manufactured in 316 grade stainless steel.

### **Powder coating**

All standard powder coating on the aluminium profiles are guaranteed for 15 years.

### **Weather strips**

All weather strips in between the glass panels are made from UV resistant material guaranteed for 5 years against UV deterioration. Soft silicone inserts to eliminate rattles and prevent water/wind penetration.

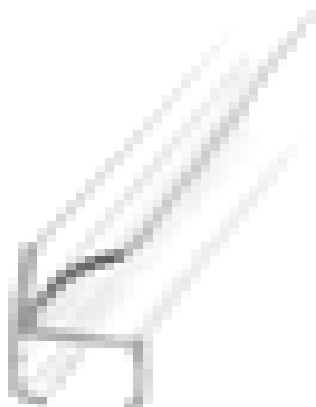



since  
1997

### **Anchors and screws**

The anchors and screws are very important for the overall structural integrity and therefore needs to be specified and certified. In general, the choice of anchors and screws depends on the load and the construction material (wood, metal, concrete) to which the system is installed. Load (horizontal and vertical) must be taken into consideration.

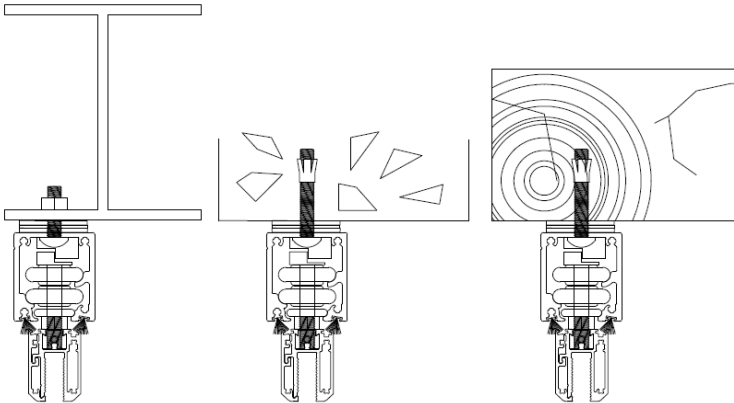

8mm button head s/steel bolt is used as standard to secure the top profile.

- |          |   |   |
|----------|---|---|
| Steel    | - | 8mm button head bolt & nut  |
| Concrete | - | 8mm button head bolt & brass anchor   |
| Concrete | - | 8mm button head bolt & brass anchor or 6mm wooden screw stepped inside the profile. |

### **Floor levels**

Outside floor level should not slope towards the inside.

Bottom sill profile will protrude with a minimum of 3mm dependant on the inside floor level.

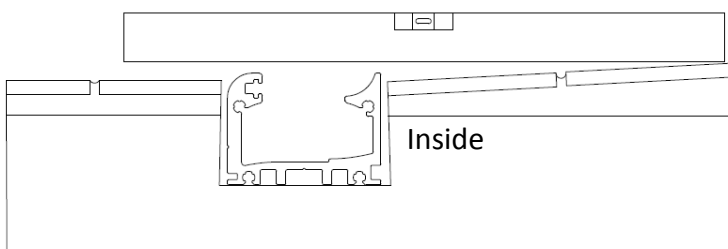



since  
1997

## **Waterproofing**

Always consult a waterproofing expert if unsure. See the drawings below as guideline.

### Waterproofing on recessed installation

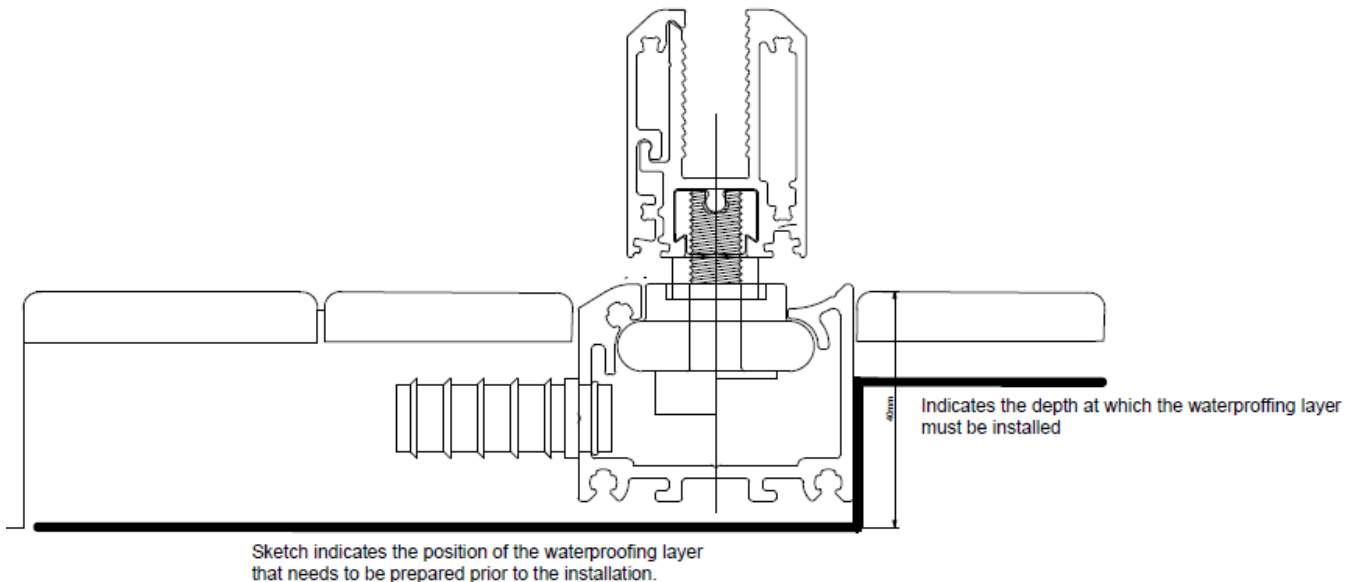

## **Drainage**

Drain pipes are used to drain any fluids, that might enter the bottom profile, away. The standard drainpipes used is a pvc tube with a 10mm outer diameter. These drainpipes are installed at 2000mm intervals along the bottom profile, draining to the outside mostly. If the drain point needs to be at a specific point off-centre from the drain hole, flexible PVC tubing is used in conjunction with the aluminium drainpipe. 12mm Holes can be drilled into the side of the profile if no drainpipes are required. Drain pipes can be installed at the bottom of the profile as well, depending on the specific installation detail. In some cases, drainpipes can only be installed on one specific point. Care should then be taken to ensure proper flow of water. Larger drain holes or more drain holes can be drilled into the side of the bottom sill profile.

When designing the installation it is very important to inform the client of the draining pipes that needs to be installed.





since  
1997

### Curtains/Blinds

The Clearview has a very short guiderarm to guide the wheels, thus ideal for fitment of curtains or blinds on the inside.

